

# LifeSmart®

Simply Brilliant

**Smart Door Lock (Classic) Model. LS101GD**  
Setting up your Smart Door Lock (Classic)  
User Guide V 1.0

## CONTENTS

<b>INTRODUCTION</b>	<b>01</b>	<b>LifeSmart App</b>	<b>25</b>
Features	01	<b>FAQ &amp; Answers</b>	<b>27</b>
Specifications	03	<b>Warranty Description</b>	<b>28</b>
Components	05	<b>Declaration</b>	<b>29</b>
Lock Body Description	07		
<b>INSTALLATION</b>	<b>09</b>		
Installation Notice	09		
Installation Instructions	11		
<b>INSTRUCTION</b>	<b>14</b>		
Initial Use	14		
Keyboard Operation	14		
Unlock / Lock Operation	14		
Finerprint Operation	16		
Password Operation	17		
NFC Operation	19		
Settings	21		

# PRODUCT INTRODUCTION

---

LifeSmart Smart Door Lock (Classic) is equipped with new type fingerprint acquisition device with higher accuracy and a faster response speed to improve security and user experience. It utilizes independent encryption safety zone to store user fingerprint data to guarantee user privacy security. It supports multiple ways to open door lock to meet multiple demands under different situations. The front panel of door lock utilizes a bezel-less design with a stylish finish and an emphasis on ergonomics.

## 1.1 Features

### 1. Multiple Ways for Access

You can open your door with fingerprint, password, NFC card, a traditional key or through LifeSmart App.

### 2. Safe Mode

It requires a combination of TWO door open methods (fingerprint, password or NFC card) to grant the access.

### 3. Anti Password Leak Lock Down

If password is entered wrong 10 times, the door lock locks down for 10 minutes automatically.

### 4 . Brute Force Attack Protection

An alarm will be triggered if the door is broken in by force.

### 5. Scramble Pin Code

You can input your correct password in order in any place in the sequence as long as it's within 24 characters.

### 6. Hostage Alarm

You can pre-set your hostage password. When an abduction happens, just input your hostage password to inform your family for help.

### 7. Bezel-less Tempered Glass Panel

Touch panel is made of tempered glass and embed within the the body for durable protection.

## 1.2 Specifications

Size	385 * 75 *33 mm (Handle excluded)
Color	Gold
Material	Zinc Alloy
Lens	F.2.5
Night Vision	Fill Flash
False Reject Rate	≤1%
False Accept Rate	≤0.001%
Compatible Lock Body	6068 Lock Body, Compatible with TDG Anti-theft Spindles
Ways of Access	Fingerprint/Password/NFC card Emergency Key

Storage	255 Fingerprints, 30 Combinations, 255 NFC Cards
Fingerprint Recognition	RF Fingerprinting Scanner
Password Length	6~12 Characters
Power	AA Batteries * 8
Emergency Power	USB Ported Power
Radio Type	CoSS
Radio Range	100m (Open Field)
Operating Temperature	-30~60°C
Operating Humidity	20~90%

### 1.3 Components

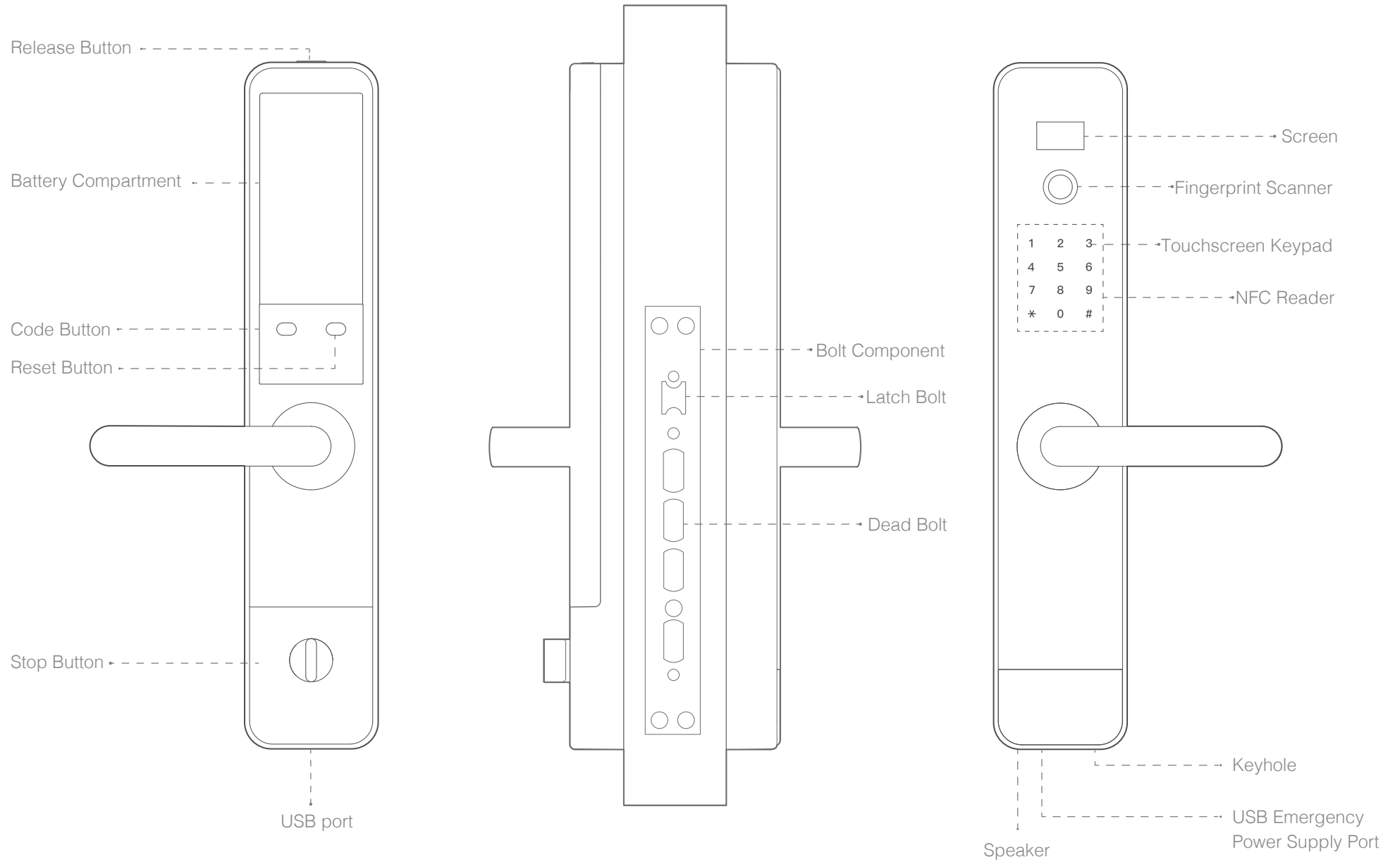

### 1.4 Lock Body Description

24 \* 240 Lock Body (Standard)

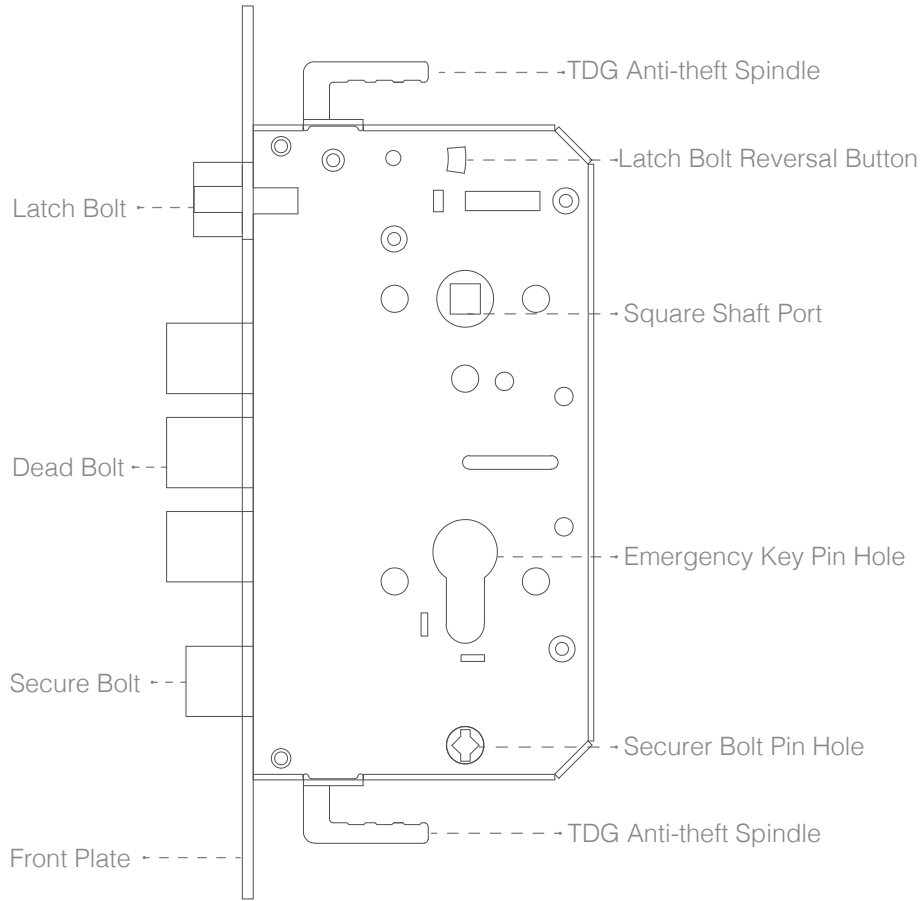

30 \* 240 Lock Body (Optional)

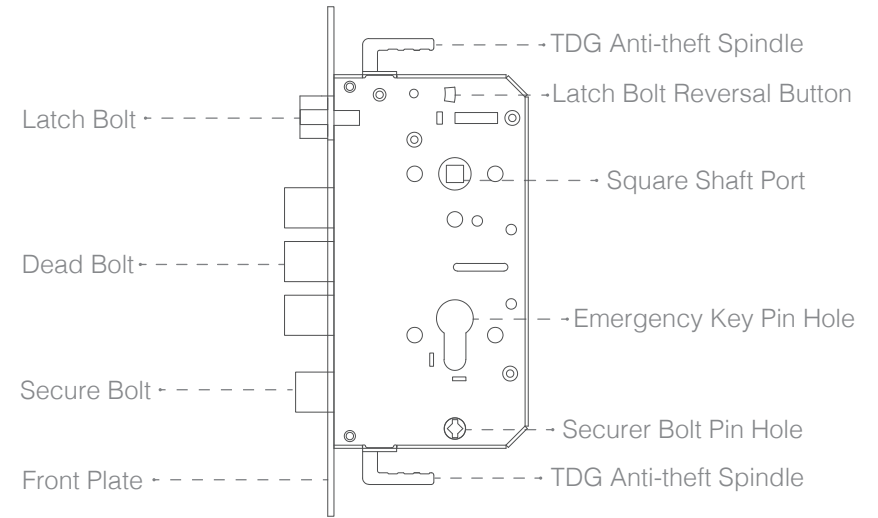

388 Lock Body (Optional)

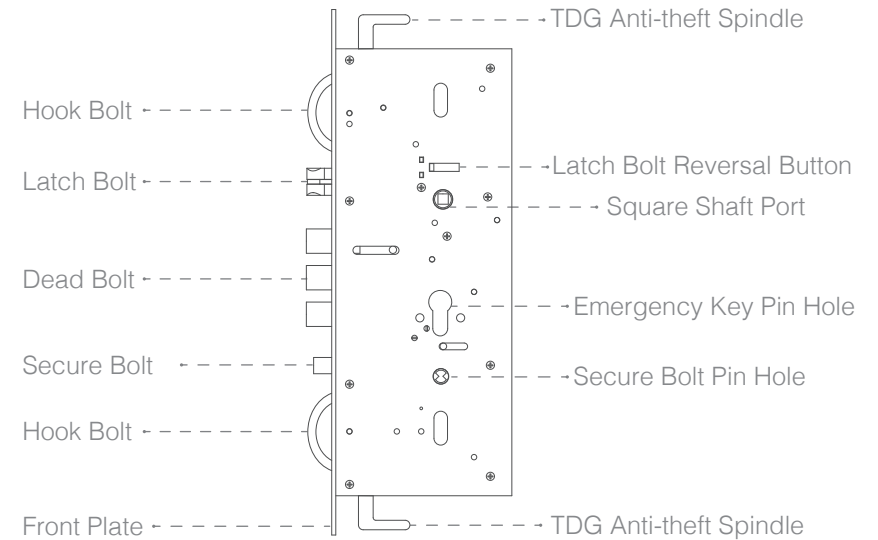

# INSTALLATION

## 2.1 Installation Notice

### 1 . Change Direction of Front Panel Handle

- ① Adjust the handle to the position as the dashed line shows (see right).
- ② Fix the orientation screw.
- ③ Twist square hole towards handle direction until it is fixed.
- ④ Same steps are applied to both front and back panels.

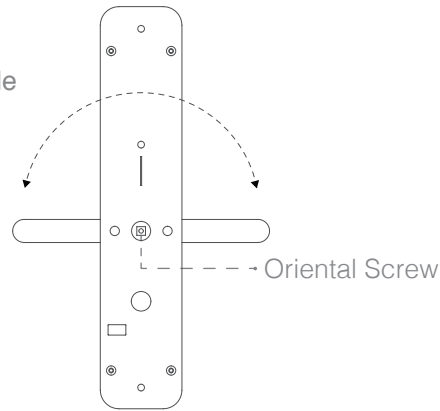

### 2 . Direction of Opening

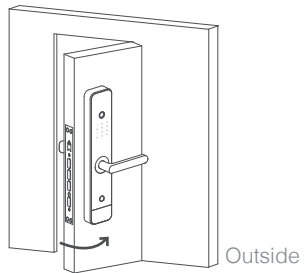

① Pull outside to right

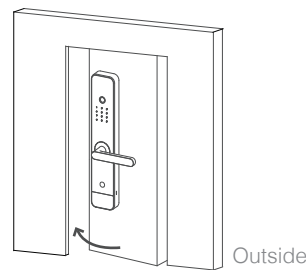

② Push inside to right

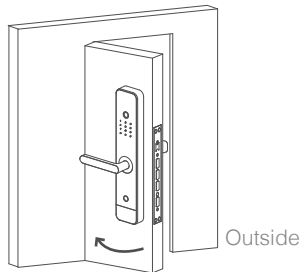

③ Pull outside to left

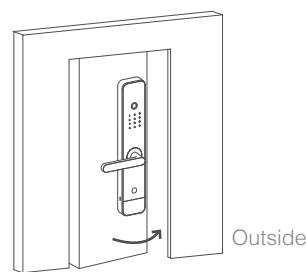

④ Push inside to left

## 3 . Door Thickness and Front Plate Length /Thickness Measurement

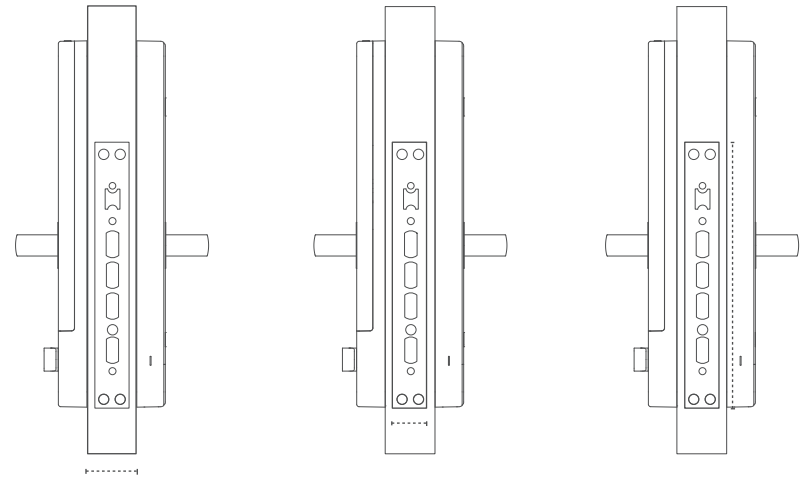

Measuring the thickness of the door

Measuring the thickness of the front plate

Measuring the length of the front plate

### ATTENTION

The lock body is compatible for doors with thickness ranged 45mm-55mm. If your door is thicker than 55cm, components will have to be customized. Please check before installation, and contact your retailer if the lock body does not fit in.

## 2.2 Installation Instructions

1 . Drill openings according to the template, and then place the lock body into door jamb.

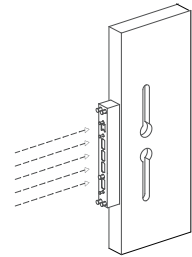

2 . Connect the TDG anti-theft spindles with the lock body.  
(Skip this step if it is a wooden door)

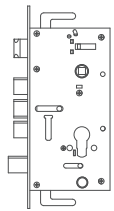

3 . Fix 4 screws on the lock body.

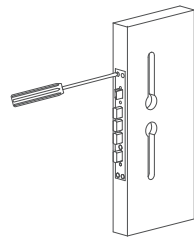

4 . Connect the threaded rod according to the thickness of your door. Install the handle in line with the direction of openings. Use a cross tip screwdriver to tighten the oriental screw and fasten the square hole towards handle.

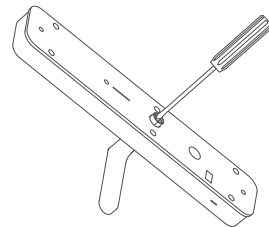

### ATTENTION

The oriental screw is on loose in the lever handle when it is shipped. Please pull it out from the right handle direction and tighten it according to your opening direction.

5 . Insert a square strip into the lock body from inside the door to outside (the longer side of the square strip facing the front plate and springs inserted both sides of the strip).

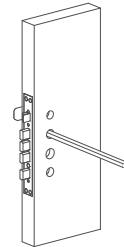
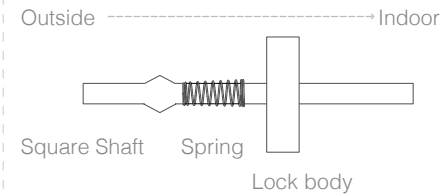

6 . Place the cable of the front panel through the opening and seal the panel.

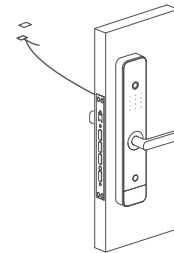

7 . Separate the back panel and its cover case (silicone pad and stainless steel cover). Place cables from front panel through the matched openings, then fix the cylinder crews.

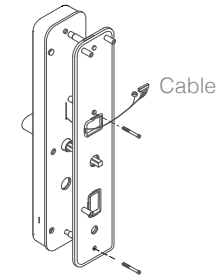

8 . Connect cables from front panel to the right sockets on back panel. Remove the cover of the battery compartment, adjust it and tighten fix 4 screws on the panel.

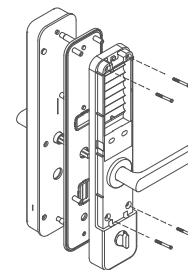



9 . Install batteries. Close battery compartment.

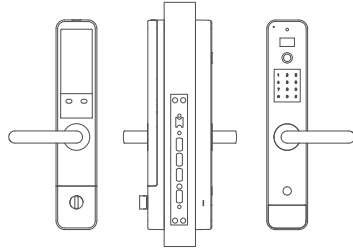
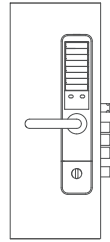

10 . Please check the handle from both sides of the door, stop button, emergency key and other components after installation to confirm the door lock working properly.

## INSTRUCTION

### 3.1 Initial Use

- 1 . Make sure that the door lock is installed properly and batteries are already placed in compartment. (AA Battery \* 8)
- 2 . Add two admin accounts to activate at least one unlocking method (from fingerprint, password and NCF card).
- 3 . Now the door lock is good to use. You can now authorize more fingerprints, passwords or NFC card to grant access.

### 3.2 Keyboard Operation

1	2	3	4	5	6	7	8	9	Back	*	0	#	-Scroll Up
4	5	6	7	8	9	Back	*	0	#	-Scroll Down			
													-Confirm

- 1 . Slide to activate keyboard, input your password and press # to finish.
- 2 . Only **2**, **8**, \* and # are lit under Admin Mode. Press **2** to **scroll up**, **8** to **scroll down**, \* to **go back**, # to **confirm**.

### 3.3 Unlock/Lock Operation

#### 1 . How to Unlock in Semi-Locked State

- Semi-Locked State : Only latch bolt is locked; the lock goes semi-locked automatically after released in 5 seconds.

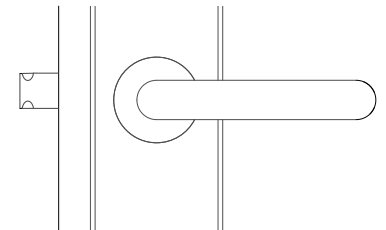

- Unlock from Inside : Push down the handle to unlock .
- Unlock from Outside : It requires fingerprint, password, NFC card or emergency key to unlock.

## 2 . How to Unlock in Full-Locked State

- Full-Locked State : latch bolt and dead bolt both locked at the same time; pull up the handle from outside the door to go full-locked.
- Unlock from Inside : Push down the handle to unlock.
- Unlock from Outside : It requires fingerprint, password, NFC card or emergency key to unlock.

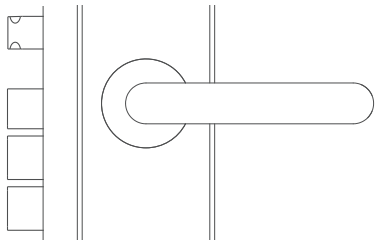

## 3 . How to Unlock in Counter Locked State

- Counter Locked State : latch bolt, dead bolt and stop button all secured; launch counter lock by switching the stop button.
- Unlock from Inside : switch the stop button back and push down the handle to unlock.
- Unlock from Outside : you can't unlock in any way.

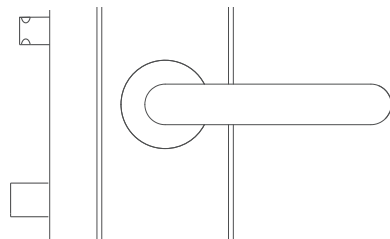

### ATTENTION

Please use the traditional metal key only if you're having an emergency.

## 3.4 Fingerprint Operation

### 1 . Fingerprint to Unlock

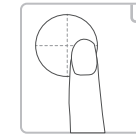
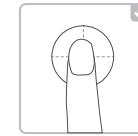

### 2 . Add a New Fingerprint

#### ► Add a User's Fingerprint

- ① Slide to active keyboard
- ② Press "\*" 2 twice
- ③ Enter Admin Mode by authorisation of an Admin's fingerprint, password or NFC card
- ④ Select "Fingerprint Management"
- ⑤ Select "Add a User"
- ⑥ Select "Empty" (no "\*" after a user's name)
- ⑦ Follow the voice instructions to complete the process

#### ► Add an Admin's Fingerprint

- ① Slide to active keyboard
- ② Press "\*" 2 twice
- ③ Enter Admin Mode by authorisation of an Admin's fingerprint, password or NFC card
- ④ Select "Fingerprint Management"
- ⑤ Select "Add an Admin"
- ⑥ Select "Empty" (no "\*" after a user's name)
- ⑦ Follow the voice instructions to complete the process

### 3 . Delete User's Fingerprint

- ① Slide to active keyboard
- ② Press "\*" 2 twice
- ③ Enter Admin Mode by authorisation of an Admin's fingerprint, password or NFC card
- ④ Select "Fingerprint Management"
- ⑤ Select "Delete a User"
- ⑥ Select the name of the user you want to delete
- ⑦ Deletion completed

### 3.5 Password Operation

#### 1 . Password to Unlock

Slide to active keyboard, input your password and finish with “#”, wait for a voice feedback and it’s unlocked.

#### 2 . Add a New Password

##### ▶ Add a User’s Password

- ① Slide to active keyboard
- ② Press “\*” 2 twice
- ③ Enter Admin Mode by authorisation of an Admin’s fingerprint, password or NFC card
- ④ Select “Password Management”
- ⑤ Select “Add a User”
- ⑥ Select “Empty” (no “\*” after a user’s name)
- ⑦ Follow the voice instructions to add a combination (6~12 characters)

##### ▶ Add an Admin’s Password

- ① Slide to active keyboard
- ② Press “\*” 2 twice
- ③ Enter Admin Mode by authorisation of an Admin’s fingerprint, password or NFC card
- ④ Select “Password Management”
- ⑤ Select “Add an Admin”
- ⑥ Select “Empty” (no “\*” after a user’s name)
- ⑦ Follow the voice instructions to add a combination (6~12 characters)

### 3 . Delete User’s Password

- ① Slide to active keyboard
- ② Press “\*” 2 twice
- ③ Enter Admin Mode by authorisation of an Admin’s fingerprint, password or NFC card
- ④ Select “Fingerprint Management”
- ⑤ Select “Delete a User”
- ⑥ Select the name of the user you want to delete
- ⑦ Deletion completed

#### ATTENTION

0001 “\*” indicates an authorised user, 0001 “\*\*” indicates an authorised admin. Only user 0001-0010 has the authority to register as an admin.

### 3.6 NFC Card Operation

#### 1 . NFC Card to Unlock

Place your NFC card at the NFC Reader area, wait for a voice feedback to unlock. You need to purchase your NFC card first, please contact your retailer for information.

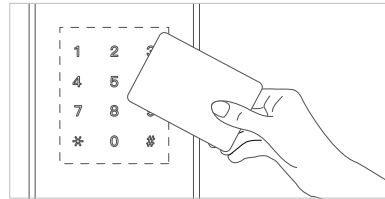

#### 2 . Add a NFC Card

##### ► Add a User's NFC Card

- ① Slide to active keyboard
- ② Press “\*” 2 twice
- ③ Enter Admin Mode by authorisation of an Admin's fingerprint, password or NFC card
- ④ Select “Fingerprint Management”
- ⑤ Select “Add a User”
- ⑥ Select “Empty” (no “\*” after a user's name)
- ⑦ Follow the voice instructions to add a NFC card

##### ► Add an Admin's NFC Card

- ① Slide to active keyboard
- ② Press “\*” 2 twice
- ③ Enter Admin Mode by authorisation of an Admin's fingerprint, password or NFC card
- ④ Select “NFC Management”
- ⑤ Select “Add an Admin”
- ⑥ Select “Empty” (no “\*” after a user's name)
- ⑦ Follow the voice instructions to add a NFC card

#### 3 . Delete User's NFC Card

- ① Slide to active keyboard
- ② Press “\*” 2 twice
- ③ Enter Admin Mode by authorisation of an Admin's fingerprint, password or NFC card
- ④ Select “NFC Management”
- ⑤ Select “Delete a User”
- ⑥ Select the name of the user you want to delete
- ⑦ Deletion completed

### 3.7 Settings

#### 1 . Safe Mode

When Safe Mode is on, you can get access only if you use any TWO of the ways for access (fingerprint, password or NFC card) at the same time.

- ① Slide to active keyboard
- ② Press “\*” 2 twice
- ③ Enter Admin Mode by authorisation of an Admin’s fingerprint, password or NFC card
- ④ Select “Settings”
- ⑤ Select “Unlock Moder”
- ⑥ Select “Safe Mode”
- ⑦ New settings applied successfully

#### 2 . Auto Lock

Set a duration between a release and an auto lock.

- ① Slide to active keyboard
- ② Press “\*” 2 twice
- ③ Enter Admin Mode by authorisation of an Admin’s fingerprint, password or NFC card
- ④ Select “Settings”
- ⑤ Select “Auto Lock Settings”
- ⑥ Select a duration (second)
- ⑦ New settings applied successfully

### 3 . Language Setting

System language and voice feedback language setting, choose from Chinese and English.

- ① Slide to active keyboard
- ② Press “\*” 2 twice
- ③ Enter Admin Mode by authorisation of an Admin’s fingerprint, password or NFC card
- ④ Select “Settings”
- ⑤ Select “Language”
- ⑥ Select a language
- ⑦ New settings applied successfully

#### 4 . Voice Feedback Setting

Voice feedback on/off.

- ① Slide to active keyboard
- ② Press “\*” 2 twice
- ③ Enter Admin Mode by authorisation of an Admin’s fingerprint, password or NFC card
- ④ Select “Settings”
- ⑤ Select “Voice Feedback”
- ⑥ Select from feedback on/off or mute
- ⑦ New settings applied successfully

## 5 . Reset to Factory Default

### ► Method 1

- ① Slide to active keyboard
- ② Press “\*” 2 twice
- ③ Enter Admin Mode by authorisation of an Admin’s fingerprint, password or NFC card
- ④ Select “Settings”
- ⑤ Select “Reset”
- ⑥ Enter password as the system instructs
- ⑦ Reset to factory default completed

### ► Method 2

- ① Open the battery compartment and remove all batteries
- ② Touch on screen until no power left
- ③ Press and hold Reset Button, and then restore batteries again
- ④ Wait for instructions on screen to finish reset

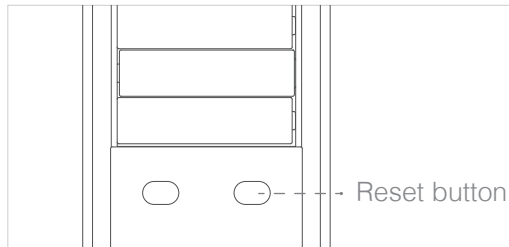

## 6 . Wireless Module

When Wireless Module is on, your door lock can be paired with LifeSmart App. You can check your door lock’s states, access records, remote control and more. Please connect your door lock to your local Smart Station and make sure you download LifeSmart App on your mobile device(s).

### Enable Wireless Module

- ① Slide to active keyboard
- ② Press “\*” 2 twice
- ③ Enter Admin Mode by authorisation of an Admin’s fingerprint, password or NFC card
- ④ Select “Settings”
- ⑤ Select “Wireless Module”
- ⑥ Select “Report Only” or “Remote Control”
- ⑦ New settings applied successfully

### Wireless Module Setting Options

- Disabled: Door lock is disconnected from your Smart Home network, you can not operate it on your LifeSmart App.
- Report Only: When enabled, you can engage all the features the LifeSmart App provides for door lock except for “Temporary Password”.
- Remote Control: When enabled, you can engage all the features the LifeSmart App provides for door lock.

# LifeSmart App

---

## 1 . Setting Up

- ① Scan the QR code below to download LifeSmart App
- ② Register and log in
- ③ Add a Smart Station first
- ④ Click “+” on the top right, then select “add new device”, choose “Video Smart Door Lock” to enter pairing procedure
- ⑤ Follow the instructions on the app to finish pairing.  
(If pairing fails, try again until it works)



LifeSmart App

### ATTENTION

- ① To experience all the features LifeSmart App provides for the door lock, it requires a LifeSmart Smart Station. If the door lock doesn't work with a Smart Station, you can only access “video call” feature on your app.
- ② To remote control your door lock via your mobile devices, ensure “Wireless Module” is on.

## 2 . Push Notifications

Get notifications on your app when your door is opened.

- ① Enter Video Smart Door Lock page on your app
- ② Click info button on the top right
- ③ Enable “Push Notification”, and select the members you want to inform in your network
- ④ Click “√” to finish setting

## 3 . Temporary User

Set up a temporary password to grant access for a visitor in a certain time period.

- ① Enter Video Smart Door Lock page on your app
- ② Click “Temporary User”
- ③ Click “+” on the top right  
Enter a name and a password, select if it's a one-time password
- ④ Click “√” to finish setting

## 4 . Video Call

Video Call feature engages a real time two-way communication with image and sound, to help you identify your guests. Guest shall press Doorbell Button to initiate.

## FAQ & Answers

---

### 1 . Why the low fingerprint recognition rate?

- ① Wrong placement of the finger when adding a new fingerprint
- ② Wrong placement of the finger when unlocking
- ③ Neither the finger nor the scanner is clean enough
- ④ Finger is too dry or too wet

### 2 . Why a new fingerprint can not be added?

- ① It is already added
- ② It is unrecognisable due to biological reasons. Please try with another finger.

### 3 . Battery problems

- ① It requires 8 AA batteries to function.
- ② If you open the door 10 times a day, the batteries last 1 year.  
(please use quality batteries)
- ③ If there's a notice saying "Low battery, please replace with new batteries", please renew the batteries as soon as possible.

### 4 . How to use emergency power?

- ① When the battery is out, you need an emergency power to supply from the emergency USB port.
- ② Wait for response after an emergency power has been supplied via USB port. Use fingerprint, password or NFC card to unlock.
- ③ Please replace the batteries as soon as possible.

## WARRANTY DESCRIPTION

---

Thank you for purchasing this LifeSmart product. In order to protect your right, please read the following content carefully: The warranty period of our company's products is one year from the date of purchase or longer if local laws impose a longer minimum term, in which case the minimum term is the warranty period.

During the warranty period, any faults caused by the product itself for quality problems that arise under normal usage, LifeSmart will provide a free replacement.







## ATTENTION

---

The following conditions are not covered by the warranty:

- Product failure or damage caused by installation, use, and maintenance that is not in accordance with the product instructions;
- Products beyond the warranty period;
- Products that have the barcode tampered with or removed;
- Devices that have been tampered with or customised outside of LifeSmart Terms of Service as on the LifeSmart APP and website;
- User-Caused damage. such as inappropriate voltage input, high temperature, accidental spillage, physical damage, etc;
- Product failure or damage caused by force majeure such as earthquakes, fires or floods;
- Product failure or damage caused by other problems except the product itself.

Please contact our customer service team before you send over for replacement through **400-886-1911**.

## DECLARATION

---

LifeSmart is a trademark of Hangzhou LifeSmart Technology Co., Ltd. As for the trademarks, product logos and product names from other companies presented within this manual, they are possessed by their own right holders. Without our written permission, no entity or individual shall extract, copy or disseminate in part or the whole of the manual contents in any form. Due to product version upgrades or other reasons, content of this manual may change. Our company reserves the right to change the contents of this manual without any notice. This manual is used only for instructional purposes. We strive to provide accurate information in this manual, but we are not able to ensure that the content of this manual is current. Statements, information and advice in this manual do not constitute any expressed or implied assurance. Updated manuals are available on our website at [www.ilifsmart.com](http://www.ilifsmart.com) or by contacting our Team.

## TECH SUPPORT

- Email  
[support@ilifsmart.com](mailto:support@ilifsmart.com)
- Telephone  
400-886-1911
- QQ  
4008861911
- Website  
[www.ilifsmart.com](http://www.ilifsmart.com)

